



SPECIFICATION SHEET

Model #:	_____ Qty: _____
Project #:	_____
Consultant:	_____

QUALITY FOOD SERVICE EQUIPMENT

PREMIUM WORK TABLES



DIMENSIONS

flat top

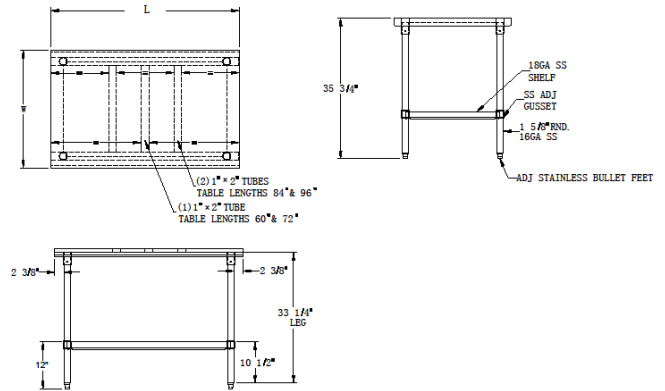

MATERIAL

- ◆ 18GA 430 stainless steel top
- ◆ Stainless steel lower shelf
- ◆ Stainless steel legs
- ◆ Stainless steel bullet feet

FEATURES

- ◆ Straight turn down on all sides
- ◆ Adjustable lower shelf (*has 6 legs)
- ◆ Adjustable bullet feet

Model#	Length	Width
TS-2418	24"	18"
TS-2424	24"	24"
TS-3018	30"	18"
TS-3024	30"	24"
TS-3030	30"	30"
TS-3618	36"	18"
TS-3624	36"	24"
TS-3630	36"	30"
TS-4818	48"	18"
TS-4824	48"	24"
TS-4830	48"	30"
TS-6018	60"	18"

Model#	Length	Width
TS-6024	60"	24"
TS-6030	60"	30"
TS-7218	72"	18"
TS-7224	72"	24"
TS-7230	72"	30"
TS-8418*	84"	18"
TS-8424*	84"	24"
TS-8430*	84"	30"
TS-9618*	96"	18"
TS-9624*	96"	24"
TS-9630*	96"	30"

(609) 642-8389 | sales@nbreqquipment.com | www.nbreqquipment.com